

## DATASHEET

**Name:** GM Pendant DC Top

**Standards:** SANS 60598-2-1

**Product Code:** PEN010

**Description:** PEN010: GM Pendant DC Top, Matt Black, Ø210mm x 350mm, Surface Mounted, E27 Lampholder, Aluminium, 220-240V AC | 50-60Hz, IP20



## Construction Specification

**Dimensions:** Ø210mm x 350mm

**Cord length:** 1,500mm

**Luminaire Colour:** Matt Black

**Installation Type:** Surface Mounted

**Environment:** Indoor

**Material:** Aluminium

**Total Weight:** 2 Kg

## Dimensions [mm]

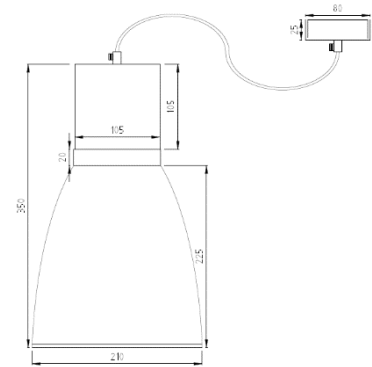

## Electrical Specifications

**Ingress Protection:** 20

**Light Source:** E27 Lampholder

**Power Supply:** 220-240V AC | 50-60Hz

**Operating Temp:** Min 5°C / Max 45°C

## Certifications



*Code	Finish
BA	Brushed Aluminium
BB	Brushed Brass
BC	Brushed Copper
MK	Matt Black
MW	Matt White
SW	Sandpaper White
SK	Sandpaper Black
Z	Bespoke colour finish as customer requests

\*Example product code: PEN010MK

## ARC Lighting CC

12 Goud Crescent, Brackenfell Industrial, Cape Town, Western Cape, 7560 South Africa

Tel: 021 981 0539

Email: [info@arclighting.co.za](mailto:info@arclighting.co.za)

Website: [www.arclighting.co.za](http://www.arclighting.co.za)

ARC Lighting CC registered in South Africa No. 1994/011049/23



The South African Quality Institute

